

# Conveying/Processing Systems

Key ways to convey, grade and feed products for processing & packaging



## Intelligent conveyors, built for performance...

- **Collection Conveyors** – collect product with minimal damage
- **Distribution Conveyors** – provide accurate distribution of product
- **Feed Conveyors** – optimize line performance with precision feeding
- **Grading, Sizing and Separating Conveyors** – perform essential functions in your line
- **Transfer Conveyors** – elevate, decline or transport product

## Smart Shaker® Vibratory Conveyors

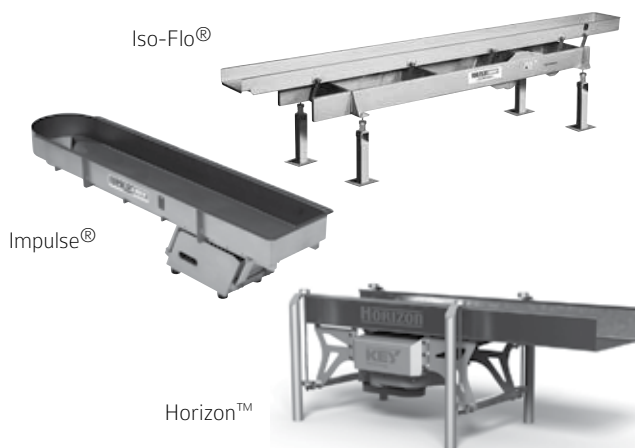

Also: Marathon™ long-distance conveyor • SmartArm® wireless monitors

## Systems to classify, transfer and remove targeted material...

- **Precision Size Grader** speeds grading for products from green beans to potato strips
- **Rotary Size Grader** removes EVM, seeds, snipped ends
- **Sliver Sizer-Remover** dejuices, deseeds, discards fines
- **Length Sizer** targets whole potatoes for specialty cuts
- **Small Piece Remover** lifts away undersized product

## Rotary Sizers/Graders

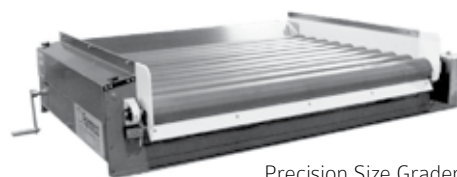

Precision Size Grader

## A program that delivers peace of mind...

Key stands behind our products and customers with a service focus that safeguards your sorters, shakers and processes – and the revenue they generate for you.

- **24/7 technical support & parts worldwide**
- **Three plan levels** to optimize sorter investments
- **RemoteMD™** real-time monitoring to boost uptime
- **Training programs** – online and instructor-led
- **Service Advisor** quarterly newsletter with product info, tips and advice to keep you at peak performance

## PROliance™ Parts and Service



Advancing Together

Corporate HQ: 150 Avery Street | Walla Walla, WA 99362 USA  
product.info@key.net | www.key.net

Information on thermal processing, upgrades and more at [www.key.net](http://www.key.net)

Contact Us At: US: +1 (509) 529 2161  
Australia: +61 (03) 8710 8200  
Europe: +31 (0) 345 50 99 00  
Mexico: +52 (442) 210 1390