

## PD Pumps



Fristam is a world renowned manufacturer of high-quality sanitary, stainless steel pumps, blenders and mixers.

### Positive Displacement Pumps

FKL Series: heavy-duty construction and hassle-free operation.

- 11 Models
- Discharge pressures up to 500 psi
- Flow rates up to 900 gpm
- Viscosities up to 1,000,000 cps

FL2 Series: low pulsation and gentle product handling.

FL3 Series: high-speed product transfer and CIP in one pump.

### Centrifugal Pumps

FP/FPX Series: reliable, high performance, and high efficiency.

- 26 Models
- Discharge pressures up to 180 psi
- Flow rates up to 900 gpm
- Viscosities up to 1,200 cps

FPR Series: traditional Fristam performance with an easy maintenance front-loading seal.

- 26 Models
- Discharge pressures up to 195 psi
- Flow rates up to 2,000 gpm
- Viscosities up to 1,200 cps

High-pressure FM & FPH/FPHP pumps: non-pulsating flow, low maintenance, and long operating life. Discharge pressures to 1,250 psi.

### Self-Priming Pumps

FZX Series: pumps CIP solution and foamy or aerated product.

- 5 Models
- Discharge pressures up to 100 psi
- Flow rates up to 400 gpm
- Viscosities up to 5,000 cps

## Centrifugal Pumps



## Shear Blenders



### Shear Blenders

For in-line mixing, blends products quickly and consistently.

- 8 Models
- Tip speeds up to 44m/s
- Flow rates up to 375 gpm
- Viscosities up to 30,000 cps

### Powder Mixers

High-performance blending of wet and dry ingredients into a fluid stream.

## Powder Mixers

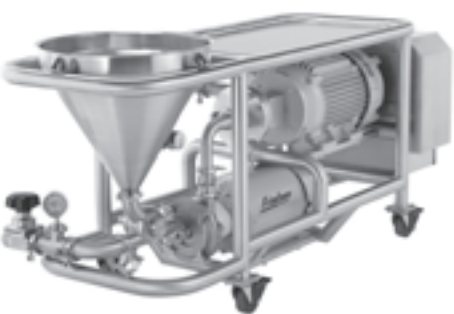

# Engineered for Lasting Performance

# **Fristam**

## **PUMPS®**

*Engineered For Lasting Performance®*

1.877.841.5001 [www.fristam.com/usa](http://www.fristam.com/usa)

